



FIAMM



FIAMM's **Monolite 12FAT125** valve-regulated, lead-acid battery is specifically designed to meet and exceed the exacting specifications of the Telecommunications industry. This "purpose-built" design philosophy, coupled with industry-leading manufacturing technology, ensures product consistency and reliable performance in a battery ideally suited to Telecommunications applications:

- 12-year plus design life
- Has passed the stringent Telcordia (Bellcore) 10-year accelerated life tests
- Good Energy Density
- Good Low-Rate Performance
- Easy Handling and Installation
- Safe Operation and Ease of Testing
- No Water Addition Needed

With its unique dual top-terminal and front-terminal design, the **12FAT125** is ideally suited for either roll-out trays or fixed-shelf systems in Remote Terminals cabinets, Huts, CEV's, and Central Offices.

Monolite

Model 12 FAT 125

12-volt, 125 Ah

DESIGN FEATURES

- ▶ **Plates and Grids:** extra-thick plates with grids cast from high purity lead-calcium-tin alloy ensure long and reliable life
- ▶ **Separator:** microporous glass mat facilitates recombination and immobilizes the electrolyte
- ▶ **Internal Connections:** heavy-duty internal straps and through-the-partition cell connections minimize internal resistance for increased energy density
- ▶ **Terminals:** threaded post terminals with brass inserts provide for high conductivity and maximum torque retention
- ▶ **Post Seals:** state-of-the-art post seals prevent seepage over a wide temperature range
- ▶ **Safety Valve:** each cell has its own one-way valve that opens at 5 psi and closes at 3 psi to allow excess gas to escape in case of over-charging
- ▶ **Flame Arrestor:** lets excess gas out while preventing any errant spark or flame from entering the battery
- ▶ **Container and Cover:** made from thick-walled ABS plastic and designed for unsurpassed mechanical strength, the cases and covers have an LOI greater than 28% and meet the flame retardancy standards of UL 94 V-0
- ▶ **Handles:** tough rope handles to aid in handling, installing and removing the batteries
- ▶ **Remote Venting System:** an optional Remote Venting System (RVS) is available for those applications requiring that the small amount of gasses generated during normal operation be vented to an external location

STANDARDS COMPLIANCE

The 12FAT125 meets the requirements of the following industry standards:

- ▶ ANSI T1.330-1997
- ▶ British Standard BS 6290 Part 4
- ▶ British Standard 6334 method FV0
- ▶ Eurobat Guide - 12 years and longer "long life"
- ▶ IEC 707 FV0
- ▶ IEC 896 Part 2
- ▶ Telcordia (Bellcore) SR-4228
- ▶ Telcordia (Bellcore) TR-NWT-000766
- ▶ Telcordia (Bellcore) TR-NWT-000909
- ▶ Telcordia (Bellcore) TR-NWT-001200
- ▶ UL 1778
- ▶ UL 94 Class V-0
- ▶ UL Recognized

Telecommunications Standby Batteries



Monolite Model 12 FAT 125

1394798
07.02

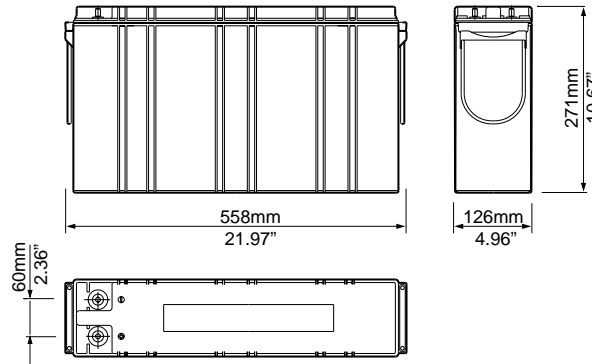

DISCHARGE AMPERES FOR 12 FAT 125 AT 77°F (25°C)

V/cell	HOURS										
	1	2	3	4	5	6	7	8	10	12	20
1.65	81.6	47.6	34.8	27.5	22.9	19.7	17.5	15.8	12.9	11.1	6.99
1.70	80.3	47.1	34.4	27.2	22.7	19.5	17.3	15.8	12.8	11.0	6.95
1.75	78.1	46.4	33.9	26.9	22.5	19.2	17.1	15.6	12.8	10.8	6.89
1.80	76.2	45.4	33.4	26.6	22.3	19.1	16.9	15.4	12.5	10.7	6.81
1.85	73.7	43.4	31.3	25.1	21.3	18.2	16.1	14.7	12.1	10.3	6.39
1.88	70.0	41.7	30.1	23.8	20.1	17.0	15.0	13.7	11.2	9.5	5.87

DISCHARGE WATTS PER CELL FOR 12 FAT 125 AT 77°F (25°C)

V/cell	HOURS										
	1	2	3	4	5	6	7	8	10	12	20
1.65	152	89.4	65.7	52.2	43.6	37.5	33.3	30.2	24.7	21.2	13.4
1.70	151	89.3	65.5	52.0	43.4	37.3	33.2	30.2	24.6	21.1	13.4
1.75	148	88.7	65.0	51.7	43.3	37.1	32.9	30.2	24.6	20.9	13.3
1.80	147	88.0	64.8	51.8	43.4	37.2	33.0	30.0	24.4	20.9	13.3
1.85	144	85.1	61.6	49.4	41.9	35.9	31.8	29.0	23.8	20.3	12.6
1.88	138	82.3	59.5	47.2	39.8	33.7	29.8	27.2	22.2	18.8	11.7

TECHNICAL SPECIFICATIONS

- ▶ **Capacities:** 125 AH at C8 to 1.75 VPC at 25°C
- ▶ **Recommended Float Voltage:** 13.56 V at 25°C
- ▶ **Temperature Compensation:** -15mV/°C
- ▶ **Maximum Charge Current:** 31 A
- ▶ **Self-Discharge at 77°F (25°C):** <2% per month
- ▶ **Short Circuit Current:** 3000 A
- ▶ **Internal Resistance:** 4.1 mohm
- ▶ **Weight:** 110.23 lb. (50.0 kg)
- ▶ **Terminals:** M8 top and M6 front
- ▶ **Terminal Torque:** 65-70 in. lbs (7.3-8.0 Nm)



FIAMM
www.fiammamerica.com

FIAMM Technologies, Inc.
One FIAMM Way
Waynesboro, GA 30830
Tel. 888-77-FIAMM (888-773-4266)